

MEDIUM-DUTY DOOR OPERATOR-MODEL MT

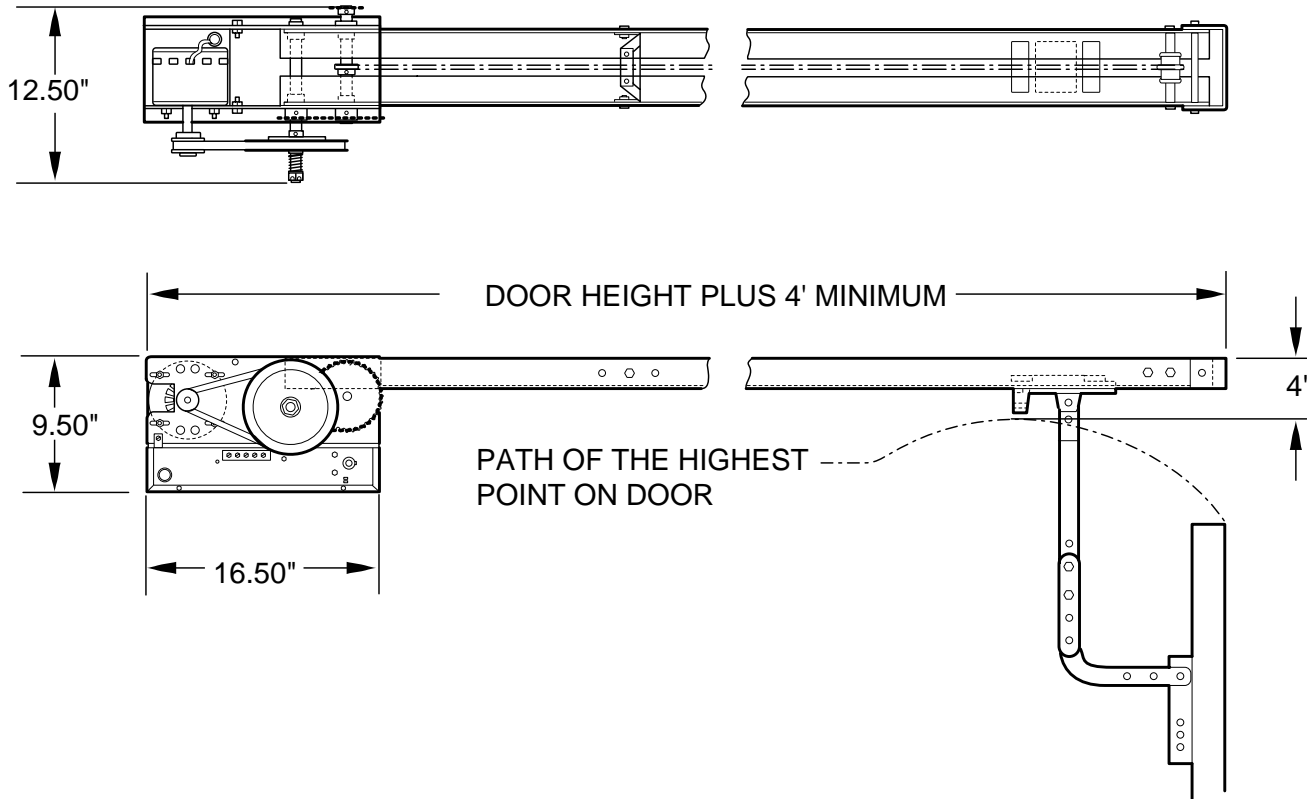

STANDARD FEATURES

Model Specific:

Work included – The electric operator will be Lift-Master Model MT as manufactured by The Chamberlain Group, Inc. Related work – Door preparation, miscellaneous or structural metal work, field electrical wiring, wire, conduit, fuses, and disconnect switches are in the scope of work of other divisions or trades.

Product:

Supply Model MT, medium-duty, cUL listed, belt drive trolley type operator(s) rated 1/2 H.P., 115 Volts, 1 Phase.

General:

Provide cUL listed electric door operator assembly, complete with electric motor and factory-prewired motor controls, internal auxiliary reversal circuit, 3-button open/close/stop control station, conduit and wiring from control to motor and accessories required for proper operation.

Electric Motor:

Motor shall be high starting torque 1/2 H.P. rated for a maximum capacity of 12 cycles per hour, protected against overload by an internal automatic reset thermal overload device.

Control Circuit:

24V NEC Class 2 Circuit with a 20 VA transformer and internal auxiliary reversal circuit designed to reverse a closing door should contact with an obstruction cause the friction clutch to slip.

Frame and Reduction:

Primary speed reduction shall be heavy-duty 4L V-belt and #41 chain and sprocket secondary. Operator shall be equipped with an adjustable friction clutch, quick disconnect door arm for manual door operation and oilite bushings on the output shaft. Track shall be 11-gauge, heavy-duty, double angle galvanized steel. Door drive shall be full #48 roller chain. Operator shall be capable of driving the door at a speed of approximately 8 to 10 inches per second.

Limit Switches:

Fully adjustable, driven linear-type limit switch mechanism shall synchronize the operator with the door. Low friction nylon limit nuts fitted on threaded steel shaft, rotating on oilite self-lubricating bronze bushings. The motor shall be removable without affecting the limit switch settings.

Trolley Assembly:

2" x 2" galvanized steel angle rails with cast aluminum trolley. Plated steel rail spacers with nylon chain-guide assembly.

Execution:

Install the motor operator in accordance with Lift-Master instructions and standards and in compliance with applicable federal, state, or local regulations.

Warranty:

Lift-Master Commercial Door Operators and accessories shall be warranted to be free of any defect in materials and workmanship for a period of two years.

Lift-Master
The Professional Line
Commercial Operators

Manufactured by:

The Chamberlain Group, Inc.
845 Larch Avenue • Elmhurst, Illinois 60126
World's Largest Manufacturer of Door Openers

For More Information Call: (800) 323-2276 or (800) 766-1188 Or Fax: (630) 530-6098 or (516) 467-2566