

MEDIUM-DUTY DOOR OPERATOR-MODEL MJ

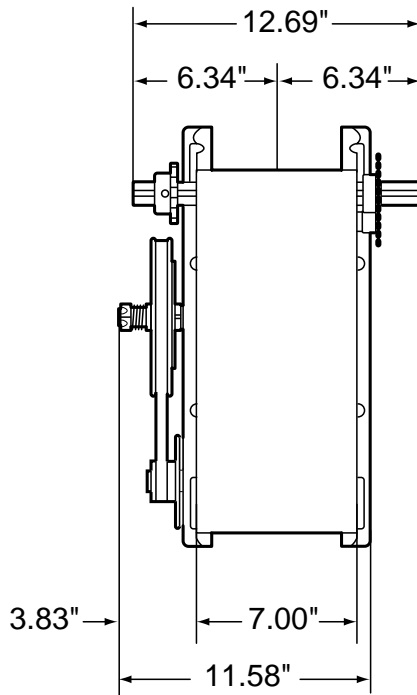

MOUNTING DIMENSIONS

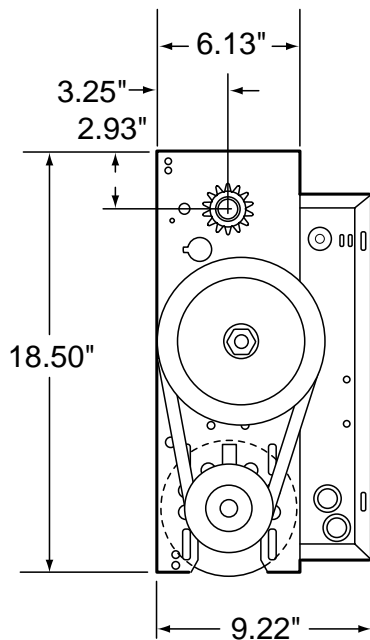
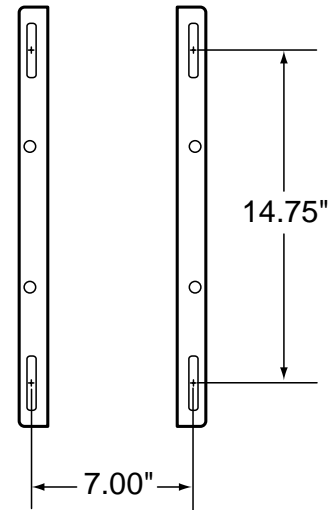

STANDARD FEATURES

Model Specific:

Work included – The electric operator will be Lift-Master Model MJ as manufactured by The Chamberlain Group, Inc. Related work – Door preparation, miscellaneous or structural metal work, field electrical wiring, wire, conduit, fuses and disconnect switches are in the scope of work of other divisions or trades.

Product:

Supply Model MJ, medium-duty, cUL listed, belt drive jackshaft type operator(s) rated 1/2 H.P., ___ Volts, ___ Phase.

General:

Provide cUL listed electric door operator assembly of size and capacity recommended by door manufacturer; complete with electric motor and factory-prewired motor controls, solenoid brake, 3-button open/close/stop control station,

conduit and wiring from control to motor and accessories required for proper operation.

Electric Motor:

Motor shall be high starting torque 1/2 H.P. rated for a maximum capacity of 12 cycles per hour, protected against overload by an internal automatic reset thermal overload device.

Control Circuit:

24V NEC Class 2 Circuit with a 20 VA transformer.

Frame and Reduction:

Primary speed reduction shall be heavy-duty 4L V-belt and #41 chain and sprocket reduced secondary. Operator shall be equipped with an adjustable friction clutch, and floor level disconnect, output and door driven sprocket shall be provided with the operator. Operator shall be capable of mounting on either left or right side of door and shall be capable of driving the door at a speed of approximately 8 to 9 inches per second.

Limit Switches:

Fully adjustable, driven linear type limit switch mechanism shall synchronize the operator with the door. Low friction nylon limit nuts fitted on threaded steel shaft, rotating on oilite self-lubricating bronze bushings. The motor shall be removable without affecting the limit switch settings.

Execution:

Install the motor operator in accordance with Lift-Master instructions and standards and in compliance with applicable federal, state or local regulations.

Warranty:

Lift-Master Commercial Door Operators and accessories shall be warranted to be free of any defect in materials and workmanship for a period of two years.

Lift-Master
The Professional Line
Commercial Operators

Manufactured by:

The Chamberlain Group, Inc.
845 Larch Avenue • Elmhurst, Illinois 60126
World's Largest Manufacturer of Door Openers

For More Information Call: (800) 323-2276 or (800) 766-1188 Or Fax: (630) 530-6098 or (516) 467-2566