

INDUSTRIAL-DUTY HOIST OPERATOR-MODEL H

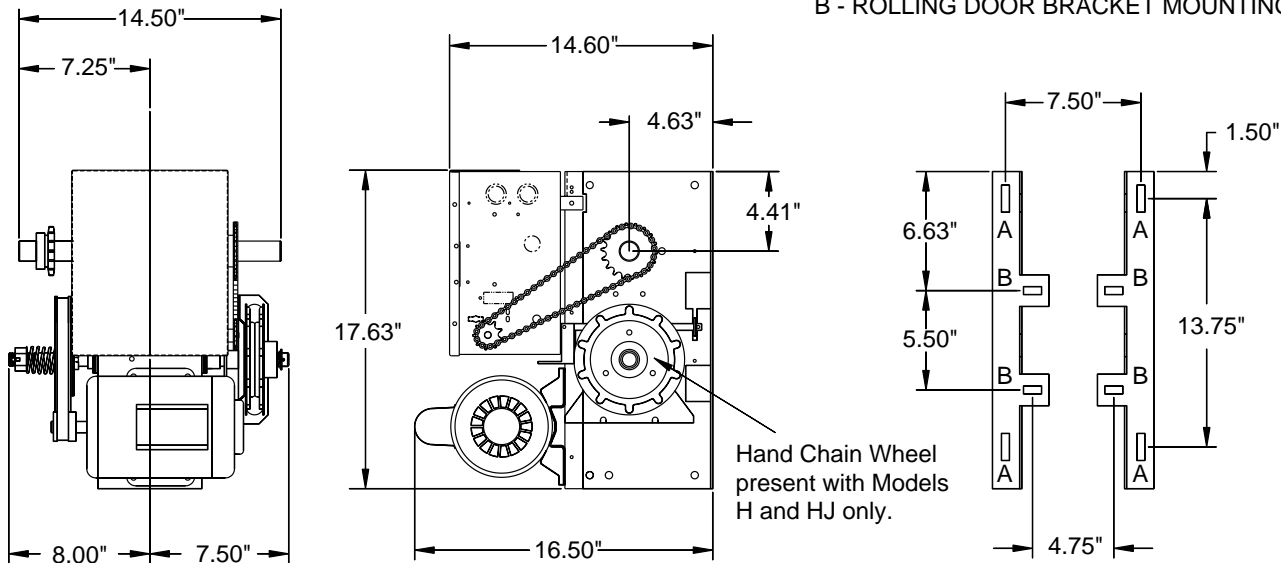

MOUNTING DIMENSIONS A - WALL MOUNTING B - ROLLING DOOR BRACKET MOUNTING



STANDARD FEATURES

Model Specific:

Work included - The electric operator will be Lift-Master Model H as manufactured by The Chamberlain Group, Inc. Related work - Door preparation, miscellaneous or structural metal work, field electrical wiring, wire, conduit, fuses and disconnect switches are in the scope of work of other divisions or trades.

Product:

Supply Model H, industrial-duty, cUL listed, belt drive jackshaft type operator(s) rated ___H.P., ___Volts, ___Phase.

General:

Provide cUL listed electric door operator assembly of size and capacity recommended by door manufacturer; complete with electric motor and factory-prewired motor controls, emergency manual chain hoist, positive locking mechanical brake, 3-button open/close/stop control station, conduit and wiring from control to motor and accessories required for proper operation.

Electric Motor:

Motor shall be high starting torque, continuous-duty, industrial type, protected against overload by a current sensing or thermal overload device.

Motor Starter, Controls, Enclosures:

Option #1: For 115V, 208-240V, or 460V: Motor Control, Control Stations, Enclosures: Motor Control shall be cUL approved micro-processor solid state type, and include a maximum run timer for motor protection. Motor control device shall be enclosed in a NEMA 1 enclosure and integral with the operator. Control enclosures shall conform to ANSI/NEMA ICS6. Open/close/stop control station shall be NEMA type 1, and shall incorporate a maintenance alert indicator to signal intervals for routine door and operator maintenance.

Special Note To Architect: For cUL approved Self-Monitoring Safety Operation, select Option #1 and add "Must include a CPS II™ Self-Monitoring Sensor to detect obstructions in the doorway."

Option #2: For 115V, 208-240V, 460V or 575V operation: Motor Starter, Controls, Enclosures: Motor starter shall be an across-the-line, mechanically interlocked, magnetic reversing contactor. Motor starting device shall be enclosed in a NEMA 1 enclosure and integral with the operator. Control enclosures shall conform to ANSI/NEMA ICS6. A NEMA type 1 open/close/stop control station shall be provided as standard equipment.

Frame and Reduction:

Primary speed reduction shall be heavy-duty 5L V-belt and chain and sprocket double reduced secondary providing mechanical braking to hold the door in position. Operator shall be equipped with an adjustable friction clutch, and floor level disconnect and emergency manual chain hoist assembly, output and door driven sprocket shall be provided with the operator. Operator shall be capable of driving the door at a speed of approximately 8 to 9 inches per second.

Limit Switches:

Fully adjustable, driven linear type limit switch mechanism shall synchronize the operator with the door. Low friction nylon limit nuts fitted on threaded steel shaft, rotating on oilite self-lubricating bronze bushings. The motor shall be removable without affecting the limit switch settings.

Execution:

Install the motor operator in accordance with Lift-Master instructions and standards and in compliance with applicable federal, state or local regulations.

Warranty:

Lift-Master Commercial Door Operators and accessories shall be warranted to be free of any defect in materials and workmanship for a period of two years.

Lift-Master
The Professional Line
Commercial Operators

Manufactured by:

The Chamberlain Group, Inc.
845 Larch Avenue • Elmhurst, Illinois 60126
World's Largest Manufacturer of Door Openers

For More Information Call: (800) 323-2276 or (800) 766-1188 Or Fax: (630) 530-6098 or (516) 467-2566