

FULL VIEW ALUMINUM DOOR - MODEL C2AL

08360/IDE
Buyline 5969

- 2-1/8" Extruded Aluminum
- DSB Glass

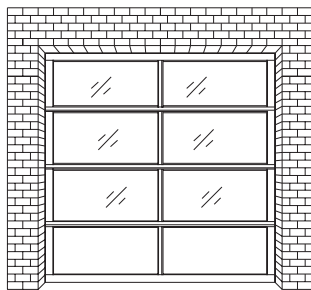
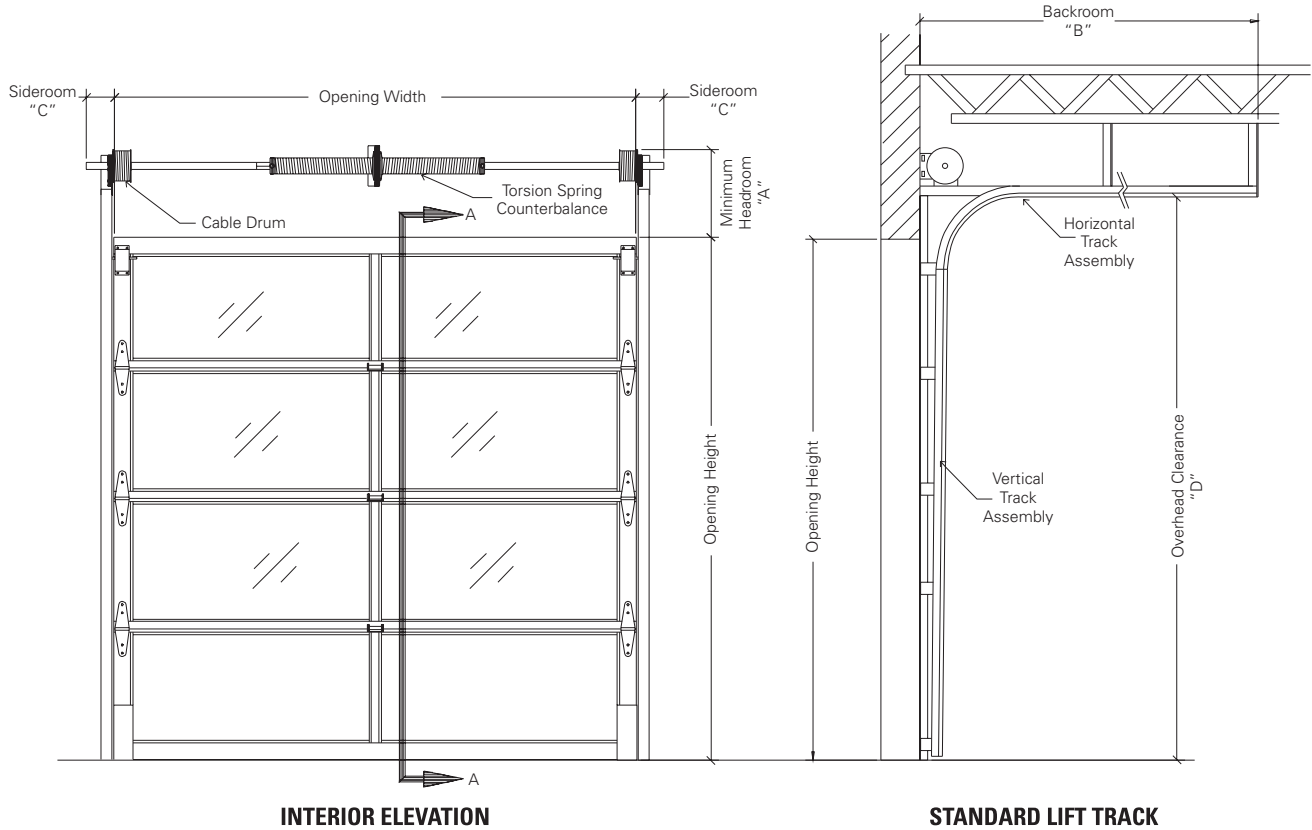

EXTERIOR ELEVATION

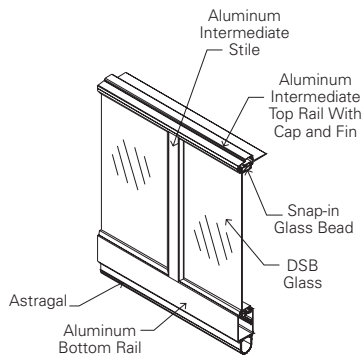

ISOMETRIC VIEW

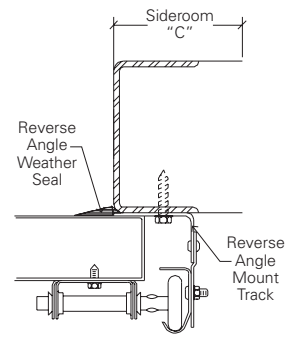

STEEL JAMB DETAIL

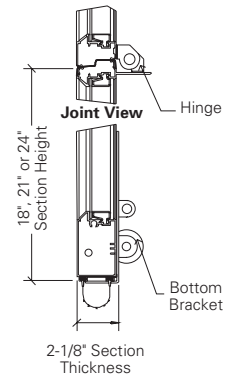

SECTION A-A
BOTTOM BRACKET VIEW



SPECIFICATIONS

PART 1 GENERAL

1.01 Section Includes

A. Upward Acting Sectional Doors, including unit sections, brackets, tracks, glazing, counter balance mechanisms, and hardware.

1.02 Related Work

A. Opening preparation, miscellaneous or structural steel, finish or field painting, electrical wires, wiring, disconnect switches, conduit are in the scope of the work of other sections or trades.

B. Submit manufacturer's product data and installation instructions for each type of sectional door. Include both published data and any specific data prepared for this project.

1.03 Single Source Responsibility

A. Provide door, tracks, motors and accessories from one manufacturer for each type of door. Provide secondary components from source acceptable to manufacturer of primary components.

PART 2 PRODUCT

2.01 Manufacturer

A. Upward Acting Sectional Doors are to be Ideal Door® Model C2AL as manufactured by Clopay Building Products Company, Inc.

2.02 Material/Construction

A. Type: 2¹/₈" (53.98 mm) thick extruded aluminum.

B. Size: Standard maximum door size is 20'2" (6.15 m) wide by 16' (4.88 m) high.

C. Section Joint: Sections to form weather-tight tongue and groove fit.

D. Material: (6053-T5) anodized or pre-painted extruded aluminum with reinforcing integral fin.

E. Finish: High luster, clear anodized or pre-painted baked-on paint, white or brown.

1. Panels: Panels and glass sealed with butyl tape secured with a locking retainer. Panels are pre-installed and shipped as one unit.

- **Intermediate/Top Sections:** DSB glass.

- **Bottom Section:** .050" (1.27 mm) aluminum sheet.*

*Optional on other sections.

2.03 Related Door Components

A. End Stiles Width:

1. 3¹/₂" (88.9 mm) for single end hinge style.

2. 4⁷/₁₆" (112.71 mm) for double end hinge style.

B. Center Stiles: 2³/₁₆" (55.56 mm) wide.

C. Intermediate Rails: 2¹³/₁₆" (71.44 mm) wide.

D. Enclosed Top and Bottom Rails: 3¹/₂" (88.9 mm) wide.

E. Hinge and Roller Assemblies: Hinges and brackets to be 14 gauge (.070", (1.78 mm) minimum) galvanized steel.

1. Ten-ball steel rollers to be full-floating ball bearing in case hardened steel races and mounted to fit the taper of the track.

2. Heavy-duty hinges and 12 gauge (.101", (2.57 mm) minimum) adjustable roller holders to be galvanized steel.

2.04 Tracks

A. Horizontal Track: To be 14 gauge (.075", (1.91 mm) minimum) galvanized steel reinforced with 13 gauge (.085", (2.16 mm) minimum) galvanized steel angles.

B. Rolled Galvanized Steel (select one): Standard lift track, vertical lift track, high lift track, follow-the-roof slope track, low headroom track provide: 2" (50.8 mm) or 3" (76.2 mm) as required.

C. Vertical Tracks: To be a minimum 16 gauge (.060", (1.52 mm) minimum) galvanized steel, tapered and mounted for wedge type closing.

D. Mounting: Interior face mounted on a prepared surface.

E. Track Mounting (select one):

1. **Bracket Mounting:** Galvanized steel mounting brackets 12 gauge (.101", (2.57 mm) minimum) thick for wood jambs.

2. **Continuous or Reverse Galvanized Steel Angle Mounting:** 12 gauge (.101", (2.57 mm) minimum) angle for steel jambs; splice plates 12 gauge (.101", (2.57 mm) minimum).

2.05 Spring Counterbalance

A. Springs: Shall be torsion type, low stress, helically-wound, oil-tempered spring on a galvanized steel tube or solid steel shaft. Wire to provide 10,000 cycles minimum.

1. 25,000 cycles

2. 50,000 cycles

3. 100,000 cycles

B. Cable Drums: Die cast aluminum.

C. Cable: Pre-formed galvanized steel aircraft cable to provide a minimum of a 7:1 safety factor.

2.06 Operation

A. Operation Shall Be: Manual push-up, chain hoist, motor operated.

B. For Manual Operation: Requiring maximum exertion of the greater of 5% of door weight or 25 lbs. (111.2 N) force to open. Use pull rope supplied.

2.07 Weatherstripping

A. Field Installed Jamb/Header Weatherstripping: Extruded vinyl, placed in moderate contact with outside of door sections.

2.08 Bottom Sections

A. Astragal Retainer: Full length, .040" (1.02 mm) aluminum.

B. Astragal: U-shaped flexible PVC vinyl.

C. Handle: To be located on second section.

D. Step Plate: 3" (76.2 mm) galvanized steel step plate to be located on bottom section.

2.09 Locking

A. Inside spring loaded slide bolt lock on end stile to securely engage slot in track.

2.10 Options

A. Removable Mullions: 2" (50.8 mm) Carry-away or Roll-away up to 14' (4.267 m) high.

PART 3 EXECUTION

3.01 Examination

A. Verify that dimensions are correct and project conditions are suitable for installation. Do not proceed with installation until unsatisfactory conditions have been corrected.

3.02 Installation

A. Installation: To be by an authorized Ideal Door representative and in accordance with manufacturer's instructions and standards.

B. Submit manufacturer's product data and installation instructions for each type of sectional upward acting door. Include both published data and any specific data prepared for this project.

Note to Specifiers... Please reference Clopay® brand model 901D.