

INSULATED STEEL PAN DOOR - MODEL C5ESS

08360/IDE
Buyline 5969

- 2" Insulated Woodgrain Embossed Ribbed Steel
- .019" Min. Exterior Skin
(equal to other manufacturer's nominal 24 gauge designation.)
- Expanded Polystyrene with Steel Backer

R-Value = 6.6
U-Value = .15

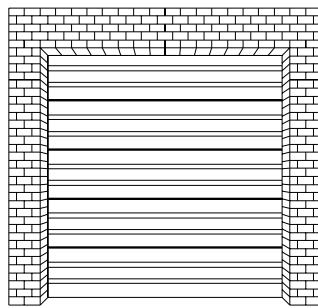
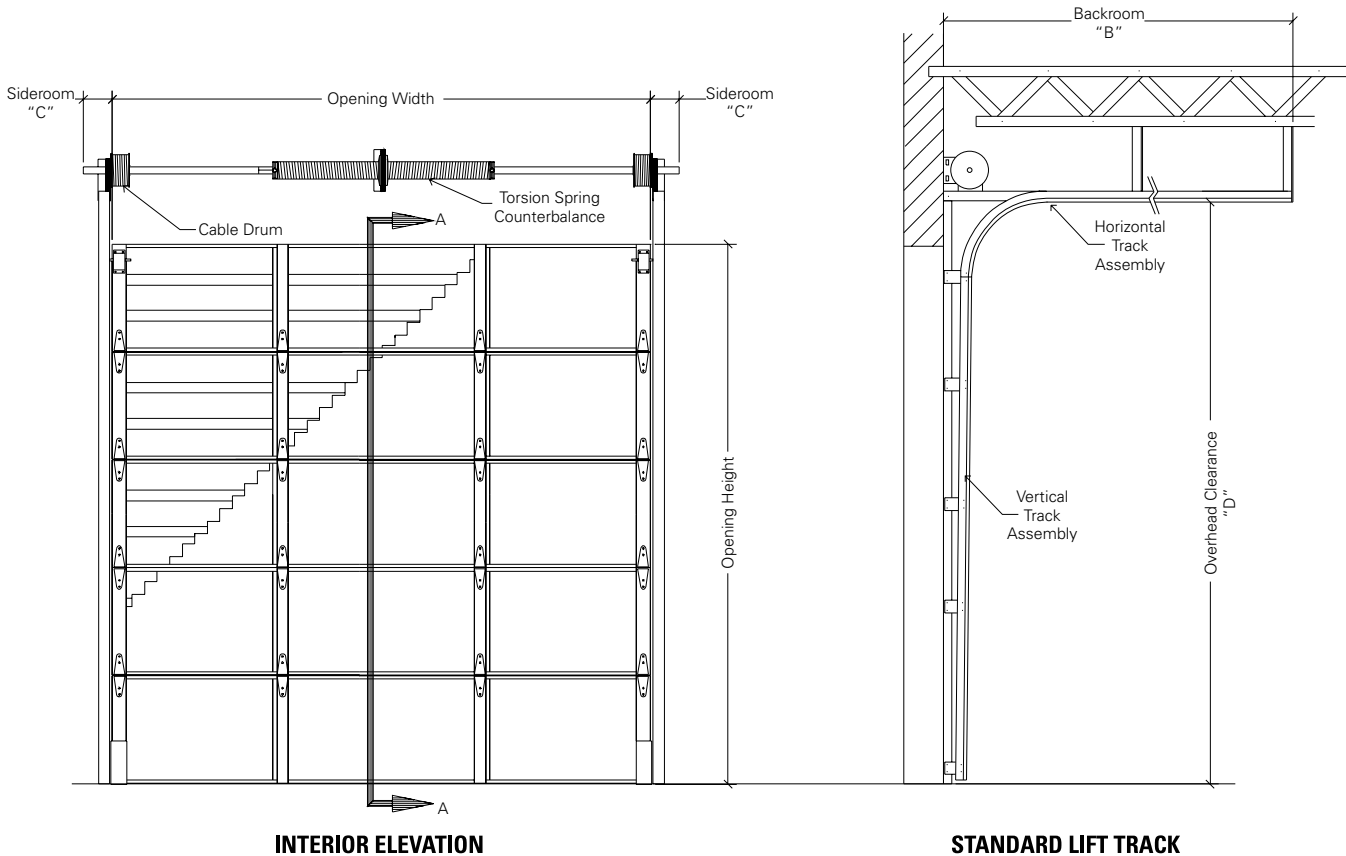

EXTERIOR ELEVATION

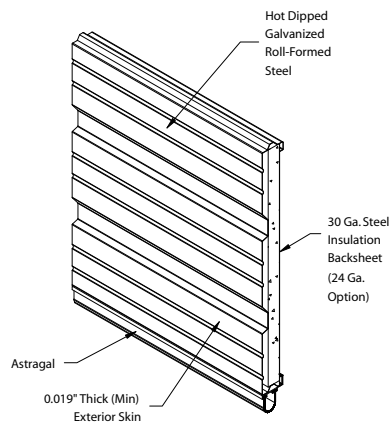

ISOMETRIC VIEW

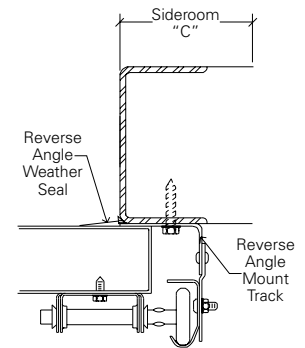

STEEL JAMB DETAIL

SPECIFICATIONS

PART 1 GENERAL

1.01 Section Includes

A. Upward Acting Sectional Steel Doors, including unit sections, brackets, tracks, glazing, counter balance mechanisms, and hardware.

1.02 Related Work

A. Opening preparation, miscellaneous or structural steel, finish or field painting, electrical wires, wiring, disconnect switches, conduit are in the scope of the work of other sections or trades.

B. Submit manufacturer's product data and installation instructions for each type of sectional door. Include both published data and any specific data prepared for this project.

1.03 Single Source Responsibility

A. Provide door, tracks, motors and accessories from one manufacturer for each type of door. Provide secondary components from source acceptable to manufacturer of primary components.

PART 2 PRODUCT

2.01 Manufacturer

A. Upward Acting Sectional Steel Doors are to be Ideal Door® Model C5ESS as manufactured by Ideal Door®, a division of Clopay Building Products.

2.02 Material/Construction

A. Type: 2" (53.98 mm) thick, roll-formed 25 gauge (.0193", (.48 mm) minimum) commercial steel.

B. Size: Standard maximum door size is 20'2" (6.10 m) wide by 16' (4.88 m) high. Maximum 320 sq. ft.

C. Section Joint: Sections to form a weather-tight tongue and groove joint.

D. Material: Hot-dipped galvanized, complying with ASTM A-924, A-653, standard lift operating style with track and hardware; complying with DASMA 102, commercial application.

E. Finish: Pre-finished exterior and interior skins with 1-mil, three-coat baked-on polyester top coat over primer on a phosphate coating.

1. Exterior Skin: Exterior woodgrain embossed steel skin with two 1/2" (12.70 mm) deep reinforcing ribs on 8" (203.20 mm) centers and six 1/8" (3.18 mm) pencil ribs on 17/8" (47.63 mm) centers. Color: white, brown.

2. Interior Skin: Interior primed and painted 30 gauge (0.012" (.30 mm) minimum) face sheet. Color: white.

2.03 Related Door Components

A. End Stiles: Galvanized steel. To have pre-punched holes for easy hardware attachment.

1. 18 gauge (.049", (1.25 mm) minimum) single end hinge style. Doors over 14'2" wide have 16 gauge as standard.

2. 16 gauge (.059", (1.49 mm) minimum) double end hinge style. (standard on doors wider than 16'2" wide)

B. Center Stiles: 18 gauge (.049", (1.25 mm) minimum).

1. Stiles and roll-formed section are fastened together with Tog-L-Loc™.

C. Hinge and Roller Assemblies: Hinges and brackets to be 18 gauge (.045", (1.14 mm) minimum) galvanized steel.

1. Ten-ball steel rollers to be full-floating ball bearing in case hardened steel races and mounted to fit the size and taper of the track.

2.04 Insulation

A. 15/8" Expanded Polystyrene: R-value = 6.6, U-value = .15.2.05 Tracks

A. Horizontal Track: To be 14 gauge (.075", (1.91 mm) minimum) galvanized steel reinforced with 13 gauge (.085", (2.16 mm) minimum) galvanized steel angles.

B. Rolled Galvanized Steel (select one): Standard lift track, vertical lift track, high lift track, follow the roof slope track, low headroom track - provide: 2" (50.8 mm) or 3" (76.2 mm) as required.

C. Vertical Tracks: To be 16 gauge (.060", (1.52 mm) minimum) galvanized steel, tapered and mounted for wedge type closing.

D. Mounting: Interior face mounted on a prepared surface.

E. Track Mounting (select one):

1. Bracket Mounting: Galvanized steel mounting brackets 12 gauge (.101", (2.57 mm) minimum) thick for wood jambs.

2. Continuous or Reverse Galvanized Steel Angle Mounting: 12 gauge (.101", (2.57 mm) minimum) angle for steel or wood jambs; splice plates 12 gauge (.101", (2.57 mm) minimum).

2.06 Spring Counterbalance

A. Springs: Shall be torsion type, low stress, helically wound, oil-tempered spring on a galvanized steel tube or solid steel shaft. Wire to provide 10,000 cycles minimum.

1. 25,000 cycles

2. 50,000 cycles

3. 100,000 cycles

B. Cable Drums: Die cast aluminum.

C. Cable: Pre-formed galvanized steel aircraft cable to provide a minimum of a 7:1 safety factor.

2.07 Operation

A. Operation Shall Be: Manual push-up, chain hoist, motor operated.

B. For Manual Operation: Requiring maximum exertion of the greater of 5% of door weight or 25 lbs. (111.2 N) force to open. Use pull rope supplied.

2.08 Weatherstripping

A. Field-Installed Section Joint Seal Tape: Neoprene foam seal, one-piece full length between joint of sections.

B. Field Installed Jamb/Header

Weatherstripping: Extruded vinyl, placed in moderate contact with outside of door sections.

2.09 Bottom Sections

A. Astragal Retainer: Full length, .040" (1.02 mm) aluminum.

B. Astragal: U-shaped flexible PVC vinyl.

C. Step Plate: High density composite combination step plate / lift handle to be located on bottom section.

2.10 Locking

A. Inside spring loaded slide bolt lock on end stile to securely engage slot in track.

1. Optional - Outside keyed five pin cylinder lock with outside key and 16-1/2" (419 mm) inside lockbar engaging slot in track.

2.11 Options

A. Removable Mullions: 2" (50.8 mm) Carry-away or Roll-away up to 14' (4.267 m) high. Swing up mullion available in 2" or 3" track up to 18" high.

B. Glazing:

1. Window Size: 24" x 6" (610 mm x 150 mm) or 24" x 12" (610 mm x 300 mm).

1. Frame to screw together polypropylene extruded frame, color to match exterior door color.

2. Glass Available (select one):

a. 1/2" Double pane insulated glass

b. 1/2" Tempered double pane insulated glass

C. Full Vision Sections: Optional Full Vision Aluminum Section.

3. Full Vision Glazing Available(select one):

a. DSB

b. 1/8" Plexiglass

c. 1/8" Tempered glass

PART 3 EXECUTION

3.01 Examination

A. Verify that dimensions are correct and project conditions are suitable for installation. Do not proceed with installation until unsatisfactory conditions have been corrected.

3.02 Installation

A. Installation: To be by an authorized Clopay representative and in accordance with manufacturer's instructions and standards.

B. Submit manufacturer's product data and installation instructions for each type of sectional upward acting door. Include both published data and any specific data prepared for this project.

Note to Specifiers...Please reference Clopay® brand model 525S.