

# INSULATED STEEL PAN DOOR - MODEL C1SS

08360/IDE  
Buyline 5969

- 2" Insulated Flush Steel
- 20 Gauge Exterior Skin
- Expanded Polystyrene with Steel Backer

R-Value = 6.6  
U-Value = .15

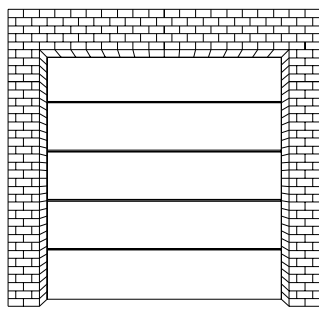
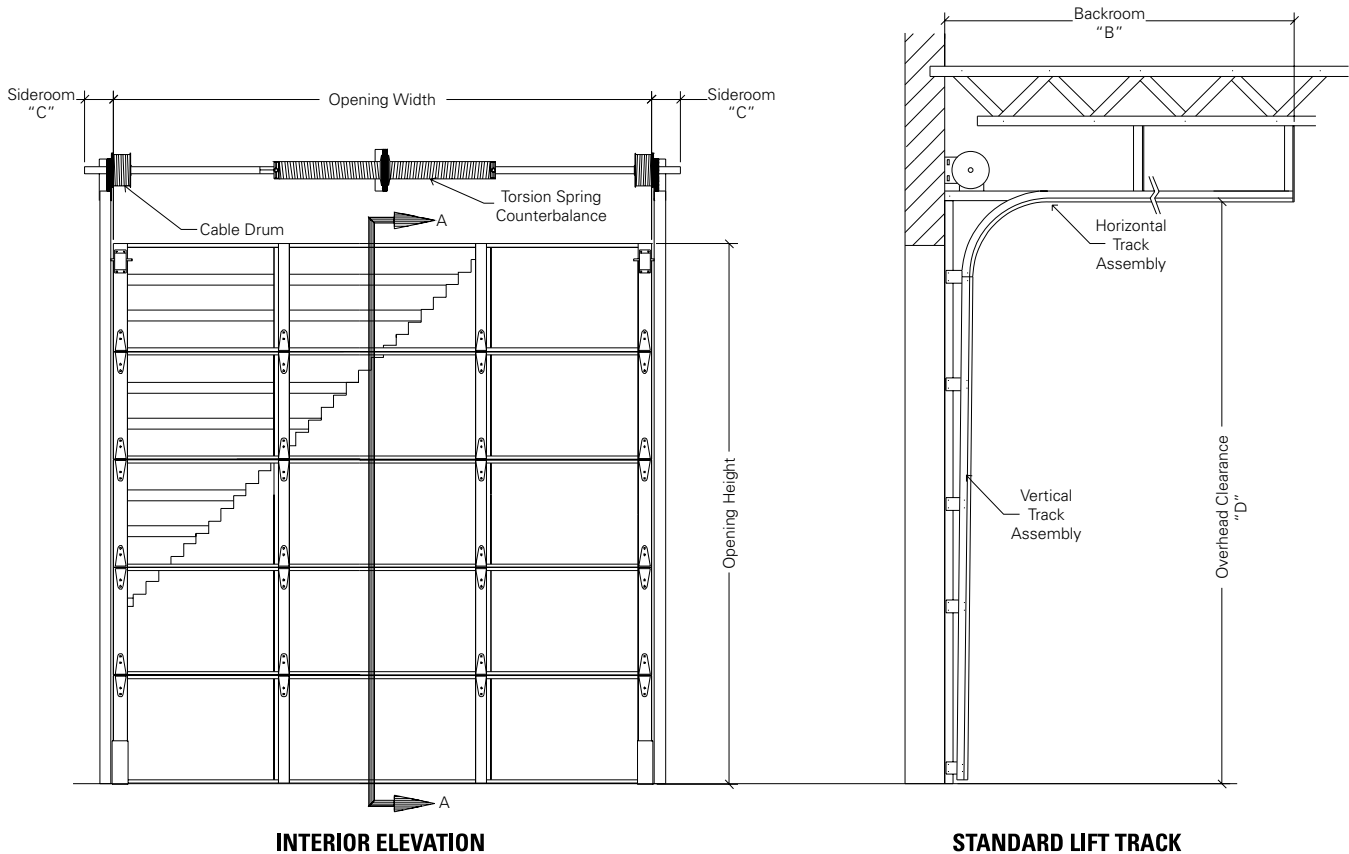

**EXTERIOR ELEVATION**

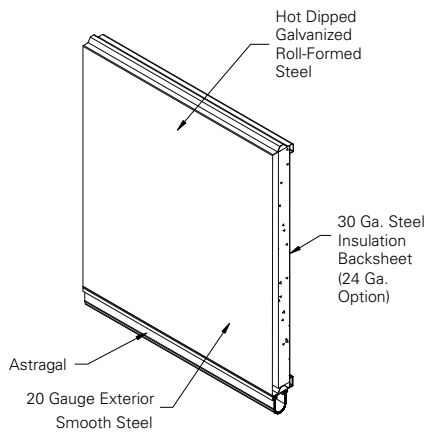

**ISOMETRIC VIEW**

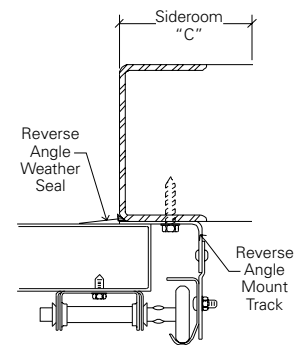

**STEEL JAMB DETAIL**

## SPECIFICATIONS

### PART 1 GENERAL

#### 1.01 Section Includes

**A. Upward Acting Sectional Steel Doors**, including unit sections, brackets, tracks, glazing, counter balance mechanisms, and hardware.

#### 1.02 Related Work

**A. Opening preparation**, miscellaneous or structural steel, finish or field painting, electrical wires, wiring, disconnect switches, conduit are in the scope of the work of other sections or trades.

**B. Submit manufacturer's product data** and installation instructions for each type of sectional door. Include both published data and any specific data prepared for this project.

#### 1.03 Single Source Responsibility

**A. Provide door, tracks, motors and accessories** from one manufacturer for each type of door. Provide secondary components from source acceptable to manufacturer of primary components.

### PART 2 PRODUCT

#### 2.01 Manufacturer

**A. Upward Acting Sectional Steel Doors** are to be Ideal Door® Model C1SS as manufactured by Ideal Door®, a division of Clopay Building Products Company, Inc.

#### 2.02 Material/Construction

**A. Type:** 2" (50.80 mm) thick, roll-formed 20 gauge (.034" minimum, .86 mm) commercial steel.

**B. Size:** Standard maximum door size is 26'2" (7.98 m) wide and 20' (6.10 m) high. Maximum 560 sq. ft.

**C. Section Joint:** Sections to form weather-tight tongue and groove fit.

**D. Material:** Hot-dipped galvanized, complying with ASTM A-924, A-653, standard lift operating style with track and hardware; complying with DASMA 102, commercial application.

**E. Finish:** Pre-finished exterior skins with 1-mil, three-coat baked-on polyester top coat over primer on a phosphate coating.

**1. Exterior Skin:** Exterior smooth skin. Color: white.

**2. Interior Skin:** Smooth steel face sheet: 30 gauge (0.012" (.30 mm) minimum). Color: white.

#### 2.03 Related Door Components

**A. End Stiles:** Galvanized steel. To have pre-punched holes for easy hardware attachment.

**1. 18 gauge (.049"/(1.25 mm) minimum) single end hinge style.**

**2. 16 gauge (.059"/(1.49 mm) minimum) double end hinge style.** (Standard for doors wider than 14'2")

**B. Center Stiles:** 18 gauge (.049"/(1.25 mm) minimum). Galvanized steel.

**1. Stiles and roll-formed section** are fastened together with Tog-L-Loc™.

**C. Hinge and Roller Assemblies:** Hinges and brackets to be 14 gauge (.070"/(1.78 mm) minimum) galvanized steel.

**1. Ten-ball steel rollers** to be full-floating ball bearing in case hardened steel races and mounted to fit the size and taper of the track.

#### 2.04 Insulation

**A. 1 3/8" Expanded Polystyrene:** R-value = 6.83, U-value = .146.

#### 2.05 Tracks

**A. Horizontal Track:** To be 14 gauge (.075"/(1.91 mm) minimum) galvanized steel reinforced with 13 gauge (.085"/(2.16 mm) minimum) galvanized steel angles.

**B. Rolled Galvanized Steel** (select one): Standard lift track, vertical lift track, high lift track, follow the roof slope track, low headroom track - provide: 2" (50.8 mm) or 3" (76.2 mm) as required.

**C. Vertical Tracks:** To be 16 gauge (.060"/(1.52 mm) minimum) galvanized steel, tapered and mounted for wedge type closing.

**D. Mounting:** Interior face mounted on a prepared surface.

**E. Track Mounting** (select one):

**1. Bracket Mounting:** Galvanized steel mounting brackets 12 gauge (.101"/(2.57 mm) minimum) thick for wood jambs.

**2. Continuous or Reverse Galvanized Steel Angle Mounting:** 12 gauge (.101"/(2.57 mm) minimum) angle for steel or wood jambs; splice plates 12 gauge (.101"/(2.57 mm) minimum).

#### 2.06 Spring Counterbalance

**A. Springs:** Shall be torsion type, low stress, helically wound, oil-tempered spring on a galvanized steel tube or solid steel shaft. Wire to provide 10,000 cycles minimum.

**1. 25,000 cycles**

**2. 50,000 cycles**

**3. 100,000 cycles**

**B. Cable Drums:** Die cast aluminum.

**C. Cable:** Pre-formed galvanized steel aircraft cable to provide a minimum of a 7:1 safety factor.

#### 2.07 Operation

**A. Operation Shall Be:** Manual push-up, chain hoist, motor operated.

**B. For Manual Operation:** Requiring maximum exertion of the greater of 5% of door weight or 25 lbs. (111.2 N) force to open. Use pull rope supplied.

#### 2.08 Weatherstripping

**A. Field-Installed Section Joint Seal Tape:** Neoprene foam seal, one-piece full length between joint of sections.

**B. Field Installed Jamb/Header Weatherstripping:** Extruded vinyl, placed in moderate contact with outside of door sections.

#### 2.09 Bottom Sections

**A. Astragal Retainer:** Full length, .040" (1.02 mm) aluminum.

**B. Astragal:** U-shaped flexible PVC vinyl.

**C. Step Plate:** High density composite step / lift handle to be located on bottom section.

#### 2.10 Locking

**A. Inside spring loaded slide bolt lock** on end stile to securely engage slot in track.

**1. Optional - Outside keyed five pin cylinder lock** with outside key and 16 1/2" (.419 m) inside lock bar engaging slot in track.

#### 2.11 Options

**A. Removable Mullions:** 2" (50.8 mm) track. Carry-away or Roll-away up to 14' (4.267 m) high. Swing-up post available for 2" or 3" track. Consult factory

**1. Pass Door:** 3 section pass door to be 2'8" (.813 m) wide, and up to 6'8" (2.03 m) high, with maximum door width of 16'2" (4.928 m) and maximum door height of 16' (4.877 m).

#### B. Glazing

**1. Window Size:** 24" x 6" (610 mm x 300 mm) or 24" x 12" (610 mm x 300 mm)

**2. Frame** to be screwed together polypropylene extruded, color to match door color.

**3. Glass Available** (select one):

**a. 1/2" Insulated glass**

**b. 1/2" Tempered insulated glass**

**C. Full Vision Sections:** Optional Full Vision Aluminum Section.

**1. Full Vision Glazing Available** (select one):

**a. DSB\***

**b. 1/8" Plexiglass\***

**c. 1/4" Wire glass\***

**d. 1/2" Insulated glass\***

\*Some restrictions apply for doors wider than 16'2". Consult Technical Services.

### PART 3 EXECUTION

#### 3.01 Examination

**A. Verify that dimensions are correct** and project conditions are suitable for installation. Do not proceed with installation until unsatisfactory conditions have been corrected.

#### 3.02 Installation

**A. Installation:** To be by an authorized Clopay representative and in accordance with manufacturer's instructions and standards.

**B. Submit manufacturer's product data** and installation instructions for each type of sectional upward acting door. Include both published data and any specific data prepared for this project.

**Note to Specifiers...**Please reference Clopay® brand model 520S.